

ELECTRIC UNIT HEATER INSTALLATION, OPERATION, AND MAINTENANCE

MODEL EUH



⚠ DANGER ⚠

- Read all instructions before using the unit.
- Failure to follow safety warnings exactly could result in serious injury, death, or property damage.
- Improper installation, adjustment, alteration, service, or maintenance can cause serious injury, death, or property damage.
- Installation and service must be performed by a qualified technician.
- Be sure to read and understand the installation, operation, and service instructions in this manual.
- This unit has hot parts inside. Do not store or use gasoline or other flammable vapors and liquids in the vicinity of this or any other appliance.
- This unit is hot when in use. To avoid burns, do not let bare skin touch hot surfaces.
- Do not operate any unit after it malfunctions. Disconnect power at the service panel and have the unit inspected by a reputable electrician before reusing.
- Do not use outdoors.
- Do not insert or allow foreign objects to enter any unit opening as this may cause electrical shock, fire, or damage to the unit.
- To prevent a possible fire, do not block air intakes or exhaust in any way whatsoever.
- Use this unit only as recommended by the manufacturer. Any other use may cause electrical shock, fire, or damage to the unit.

IMPORTANT INSTRUCTIONS

SAVE THESE INSTRUCTIONS

TABLE OF CONTENTS

GENERAL INFORMATION	3
Important Safety Information	3
Warranty	4
Certification	4
Installation Codes	4
Unit Location	4
Mounting Height	4
Heater Throw	5
Dimensions	6
Weights	7
Clearances	7
INSTALLATION	7
Unpacking and Inspection	7
Pre-Installation Checklist	7
Unit Suspension	8
Suspension of Unit Using Option CK8 Two-Point Suspension Kit	8
Suspension of Unit Using Field-Supplied Threaded Rods	9
Suspension of Unit Using Wall-Mounting Bracket	9
Suspension of Unit Using Option CK22 Ceiling Suspension Kit	9
Electrical Connections	10
Supply Wiring Connection	10
Control Connections	12
CONTROLS	13
Disconnect Switch	13
Fan Motor	13
Thermostat	13
Air Proving Pressure Switch	13
High Temperature Limit Switch	13
Multiple Unit Control	13
OPERATION	14
Pre-Startup Checklist	14
Startup	14
MAINTENANCE	14
Service Checklist	15
Maintenance Procedures	15
Electrical Component Replacement	15
Fan and Motor Assembly Maintenance	15
TROUBLESHOOTING	16
APPENDIX: WIRING DIAGRAMS	17
INSTALLATION RECORD (TO BE COMPLETED BY INSTALLER)	24

GENERAL INFORMATION

- This unit has been tested for capacity and efficiency so as to provide many years of safe and dependable comfort providing it is properly installed and maintained. With regular maintenance, this unit will operate satisfactorily year after year. Abuse, improper use, and/or improper maintenance can shorten the life of the unit and create unsafe hazards.
- To achieve optimum performance and minimize equipment failure, it is recommended that periodic maintenance be performed on this unit. The ability to properly perform maintenance on this equipment requires certain tools and mechanical skills.

Important Safety Information

Please read all information in this manual thoroughly and become familiar with the capabilities and use of your appliance before attempting to operate or maintain this unit. Pay attention to all dangers, warnings, cautions, and notes highlighted in this manual. Safety markings should not be ignored and are used frequently throughout to designate a degree or level of seriousness.

DANGER: A danger statement describes a potentially hazardous situation that if not avoided, will result in severe personal injury or death and/or property damage.

WARNING: A warning statement describes a potentially hazardous situation that if not avoided, can result in severe personal injury and/or property damage.

CAUTION: A caution statement describes a potentially hazardous situation that if not avoided, can result in minor or moderate personal injury and/or property damage.

NOTE: A note provides important information that should not be ignored.

DANGER

Read these instructions carefully before installation and operation of the unit. Failure to adhere to the instructions could result in fire, electric shock, serious personal injury, death, or property damage. Review frequently for continuing safe operation and instruction of future users, if necessary.

WARNING

- Installation should be done by a qualified agency in accordance with these instructions. The qualified service agency installing this unit is responsible for the installation.
- This appliance is not intended for use by persons with reduced physical, sensory, or mental capabilities or lack of experience and knowledge, unless they have been given supervision or instruction concerning use of the appliance by a person responsible for their safety.
- Children should be supervised to ensure that they do not play with the appliance.

CAUTION

- The thermostat should not be considered an infallible device in cases where maintaining a temperature is considered critical. In these particular cases, it is imperative to add a monitoring system to avoid the consequences of a thermostat failure.
- This unit is not approved for use in corrosive atmospheres, wet or very humid locations such as marine green house, or chemical storage areas.
- To prevent damage to the unit or to its internal components, it is recommended that two wrenches be used when loosening or tightening nuts. Do not over tighten!

GENERAL INFORMATION—CONTINUED

Warranty

Refer to the limited warranty form in the literature bag provided with the unit. The warranty is void if:

- Wiring is not in accordance with the diagram furnished with the unit.
- The unit is installed without proper clearance to combustible materials.
- The air delivery system is modified.

Certification

This unit is listed by Intertek to UL 2021 and CSA C22.2 #46 for use in the US and Canada.

Installation Codes

This unit must be installed in accordance with local building codes. Local authorities having jurisdiction should be consulted before installation is made to verify local codes and installation procedure requirements.

Unit Location

⚠ CAUTION ⚠

Do not locate the unit where it may be exposed to water spray, rain, or dripping water.

For best results, the unit should be located with certain rules in mind:

- Units should always be arranged to blow toward or along exposed wall surfaces, if possible. Where two or more units are installed in the same room, a general scheme of air circulation should be maintained for best results.
- Suspended heaters are most effective when located as close to the working zone as possible, and this fact should be kept in mind when determining the mounting heights to be used. However, care should be exercised to avoid directing the discharged air directly on the room occupants.
- Partitions, columns, counters, or other obstructions should be taken into consideration when locating the unit so that a minimum quantity of airflow will be deflected by such obstacles.
- When units are located in the center of the space to be heated, the air should be discharged toward the exposed walls. In large areas, units should be located to discharge air along exposed walls with extra units provided to discharge air in toward the center of the area.

Mounting Height

⚠ WARNING ⚠

If touched, the internal surfaces that are accessible from outside the unit will cause burns. Suspend the unit a minimum of 6 feet (1.8 meters) above the floor.

In general, a unit should be located 6–14 feet (1.8–4.3 meters) above the floor. At those points where infiltration of cold air is excessive, such as at entrance doors and shipping doors, it is desirable to locate the unit so that it will discharge directly toward the source of cold air from a distance of 15–20 feet (4.6–6.1 meters).

Heater Throw

Figure 1 shows throw patterns and **Table 1** lists throw distances for units suspended at varying mounting heights.

H = the distance from the bottom of the heater to the floor

X = the distance from the heater to the start of floor coverage

Y = the distance from the heater to the end of floor coverage

Z = the distance at which air velocity drops below 50 feet (15.2 meters) per minute

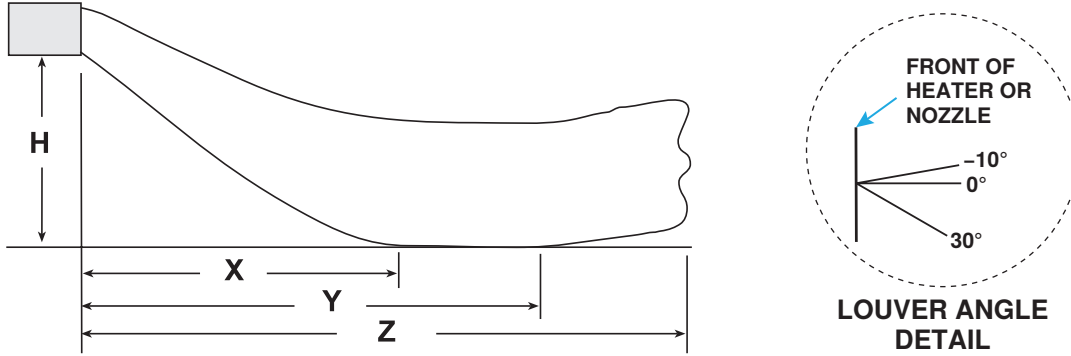

Figure 1. Heater Throw Patterns (Refer to Table 1)

		Table 1. Heater Throw Distances with Standard Horizontal Louvers							
Dimension H* (Feet (Meters))	Louver Angle* and Dimension*	Unit Size (kW)							
		3	5	7	10	15	20	25	30
		Feet (Meters)							
6 (1.8)	Angle	36°	27°	27°	27°	22°	22°	22°	22°
	X	4 (1.2)	5 (1.5)	7 (2.1)	6 (1.8)	13 (4.0)	11 (3.4)	10 (3.0)	10 (3.0)
	Y	8 (2.4)	13 (4.0)	15 (4.6)	14 (4.3)	19 (5.8)	23 (7.0)	28 (8.5)	27 (8.2)
	Z	18 (5.5)	22 (6.7)	36 (11.0)	36 (11.0)	37 (11.3)	37 (11.3)	42 (12.8)	41 (12.5)
8 (2.4)	Angle	—	36°	34°	30°	27°	27°	27°	27°
	X	—	5 (1.5)	9 (2.7)	6 (1.8)	14 (4.3)	11 (3.4)	9 (2.7)	8 (2.4)
	Y	—	10 (3.0)	15 (4.6)	14 (4.3)	19 (5.8)	28 (8.5)	28 (8.5)	28 (8.5)
	Z	—	16 (4.9)	32 (9.8)	36 (11.0)	37 (11.3)	39 (11.9)	39 (11.9)	39 (11.9)
10 (3.0)	Angle	—	—	36°	36°	32°	32°	32°	32°
	X	—	—	6 (1.8)	6 (1.8)	13 (4.0)	12 (3.7)	8 (2.4)	9 (2.7)
	Y	—	—	15 (4.6)	14 (4.3)	18 (5.5)	28 (8.5)	27 (8.2)	25 (7.6)
	Z	—	—	26 (7.9)	34 (10.4)	34 (10.4)	38 (11.6)	36 (11.0)	36 (11.0)
12 (3.7)	Angle	—	—	36°	36°	45°	45°	36°	36°
	X	—	—	12 (3.7)	10 (3.0)	11 (3.4)	10 (3.0)	12 (3.7)	10 (3.0)
	Y	—	—	14 (4.3)	15 (4.6)	16 (4.9)	22 (6.7)	24 (7.3)	22 (6.7)
	Z	—	—	20 (6.1)	33 (10.0)	27 (8.2)	31 (9.4)	34 (10.4)	34 (10.4)
14 (4.3)	Angle	—	—	—	—	—	—	45°	45°
	X	—	—	—	—	—	—	12 (3.7)	12 (3.7)
	Y	—	—	—	—	—	—	18 (5.5)	16 (4.9)
	Z	—	—	—	—	—	—	25 (7.6)	25 (7.6)

*See **Figure 1**.

Weights

Table 3. Weights							
Unit Size (kW)							
3	5	7	10	15	20	25	30
Pounds (kg)							
49 (23)	50 (23.5)	51 (24)	53 (25)	82 (38)	92 (42)	97 (44)	101 (46)

Clearances

⚠ DANGER ⚠

Keep combustible materials like furniture, pillows, bedding, papers, clothes, and curtains at least 36 inches (915 mm) away from the front of the unit.

The unit must be located so that the clearances listed in [Table 4](#) are provided for with regards to inspection and service and for proper spacing from combustible construction. Clearance to combustibles is defined as the minimum distance from the unit to a surface or object for which it is necessary to ensure that a surface temperature of 117°F (65°C) above the surrounding ambient temperature is not exceeded. Refer to the dimensions listed in [Table 2](#) and shown in [Figure 2](#) when determining clearances to combustibles.

Table 4. Clearances to Combustibles	
Unit Surface	Minimum Clearance (Inches (mm))
Top	1 (25)
Access panel	21 (533)
Non-access side	1 (25)
Bottom*	1 (25)
Rear (from fan motor)	18 (457)

*Suspend the unit so that the bottom is a minimum of 6 feet (1.8 meters) above the floor.

INSTALLATION

Unpacking and Inspection

The unit was test-operated and inspected at the factory prior to crating and was in operating condition. If, upon removing it from its crate, the unit has been found to have incurred any damage in shipment, document the damage with the transporting agency and contact an authorized Factory Distributor. If you are an authorized Distributor, follow the FOB freight policy procedures.

Pre-Installation Checklist

- Check the rating plate for the electrical characteristics of the unit to ensure that they are compatible with the electric supply at the installation site.
- Read this manual and become familiar with the installation requirements.
- If you do not have knowledge of local requirements, check with the local agencies who might have requirements concerning this installation.
- Before beginning, make preparations for necessary supplies, tools, and manpower.
- Check to see if there are any field-installed options (refer to [Table 5](#)) that need to be assembled/installed prior to unit installation. Ensure that all options ordered are at the installation site. Instructions are in this manual or in the shipped-separate option package.
- The wall-mounting bracket is shipped with the unit. If the unit is to be mounted on a wall, ensure that the required field-supplied hardware is available (refer to [Suspension of Unit Using Wall-Mounting Bracket](#) section).

INSTALLATION—CONTINUED

Pre-Installation Checklist—Continued

Table 5. Field-Installed Options	
Option	Description
CK8	Adapts 3/8-inch hangers for two-point suspension from 1-inch threaded pipe
CK22	Angle brackets for low ceiling mounting (does not include hanger rods)
CL1	Single-stage thermostat
CL22	Two-stage thermostat
CL31, CL32	Multiple unit control: option CL31 includes components for one control unit and one additional unit—option CL32 includes components for each additional non-control unit
CL90	BACnet-capable thermostat
CM1	Locking cover for CL1 thermostat
CM1B	Locking cover for CL22 thermostat
CM3	Bracket assembly for mounting thermostat on unit
CN3F	Remote ON/OFF switch in 2 × 4 box
IT13	Unit-mounted thermostat

Unit Suspension

⚠ WARNING ⚠

Before suspending the unit, check the supporting structure to be used to verify that it has sufficient load-carrying capacity to support the weight of the unit (refer to [Weights](#) section). DO NOT add additional weight to a suspended unit.

⚠ CAUTION ⚠

When the unit is lifted for suspension, support the bottom of the unit with plywood or other appropriately placed material. If the bottom is not supported, damage could occur.

The unit is designed to be suspended using two-point suspension. A 3/8-16 threaded nut retainer is located at each suspension point. The unit may be suspended using either 3/8-inch threaded rods, a hanger kit option package, or the wall-mounting bracket shipped with the unit.

Suspension of Unit Using Option CK8 Two-Point Suspension Kit

Option CK8 allows the unit to be suspended using two swivel connectors connected to 1-inch pipe. Attach the swivel connectors at the 3/8-16 threaded nut retainers. Ensure that the swivel connectors are locked to the unit as shown in [Figure 3](#).

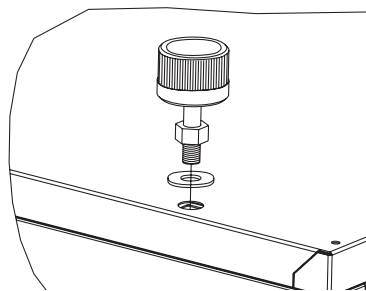

Figure 3. Option CK8 Two-Point Suspension Kit

Suspension of Unit Using Field-Supplied Threaded Rods

The unit may be suspended from 3/8-inch threaded rods using two-point suspension. The recommended maximum rod length is 6 feet (1.8 meters). The length of the threaded rod extending into the unit **MUST NOT** exceed 1/2 inch (13 mm). Ensure that the threaded rods are locked to the unit as shown in **Figure 4**.

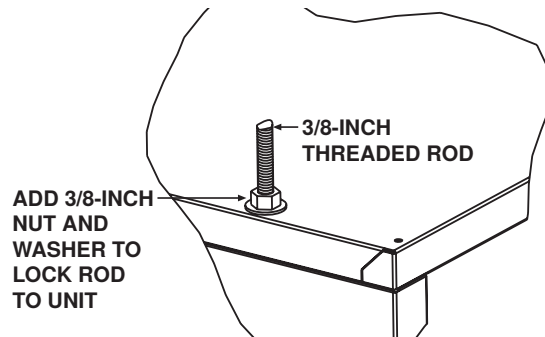

Figure 4. Unit Suspension Using Field-Supplied Threaded Rods

Suspension of Unit Using Wall-Mounting Bracket

Secure the wall-mounting bracket shipped with the unit as shown in **Figure 5**. The bracket is secured to the unit at the 3/8-16 threaded nut retainers using field-supplied 1- to 2-inch-long 3/8-16 bolts. Secure the mounting bracket to the wall using field-supplied hardware.

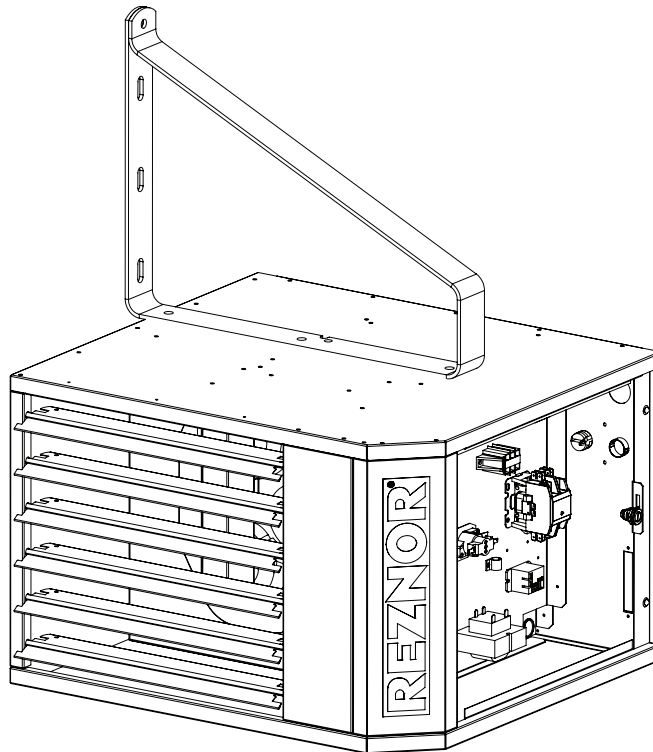

Figure 5. Unit Suspension Using Wall-Mounting Bracket

Suspension of Unit Using Option CK22 Ceiling Suspension Kit

Option CK22 allows the unit to be installed 1 inch from the ceiling without hanger rods. Refer to the installation instructions provided with the kit.

INSTALLATION—CONTINUED

Electrical Connections

⚠ CAUTION ⚠

- Ensure that Ground Fault Overcurrent Protection (GFOC) and the Short Circuit Current Rating (SCCR) are adequate and provided for at the installation location.
 - Ensure that all wiring is in accordance with the wiring diagram (refer to [APPENDIX: WIRING DIAGRAMS](#)) provided with the unit.
 - All electrical wiring and connections, including electrical grounding **MUST BE** made in accordance with the *National Electric Code* (ANSI/NFPA No. 70, latest edition) or, in Canada, the *Canadian Electric Code* (Part 1, CSA C.22.1, latest edition). In addition, the installer should be aware of any local ordinances that might apply.
 - All external wiring **MUST BE** within approved conduit and have a minimum temperature rise rating of 140°F (60°C). Conduit must be run so as not to interfere with the access panel.
-

Supply Wiring Connection

NOTE: A dedicated line voltage supply with a disconnect switch should be run directly from the main electrical panel to the unit.

1. Check rating plate for supply voltage and current requirements.
-

NOTE: IMPORTANT (BEFORE CONNECTING THE SUPPLY WIRING): Determine if units with option AK6E or AK44 require field-modification of the transformer or contactor wiring.

2. If required, modify transformer or contactor wiring as follows:
 - a. All unit sizes with voltage option AK6E are factory-wired for 240V supply. Field-modification to unit wiring is required for 208V applications. Refer to wiring diagram to change white transformer wire from 240 terminal to 208 terminal.
 - b. Unit sizes 3–10 with voltage option AK44 are factory-wired for 208V/240V 1-phase supply. Field-modification to unit wiring is required for 3-phase applications. Refer to wiring diagram to change black contactor wires as follows:
 - (1) Loosen terminal screws T1, T2, and T3 on 3-pole contactor (see [Figure 6](#)) terminals.
 - (2) Disconnect black wires from T1 and T2 terminals and connect them to T3 terminal.
 - (3) Tighten all terminal screws.

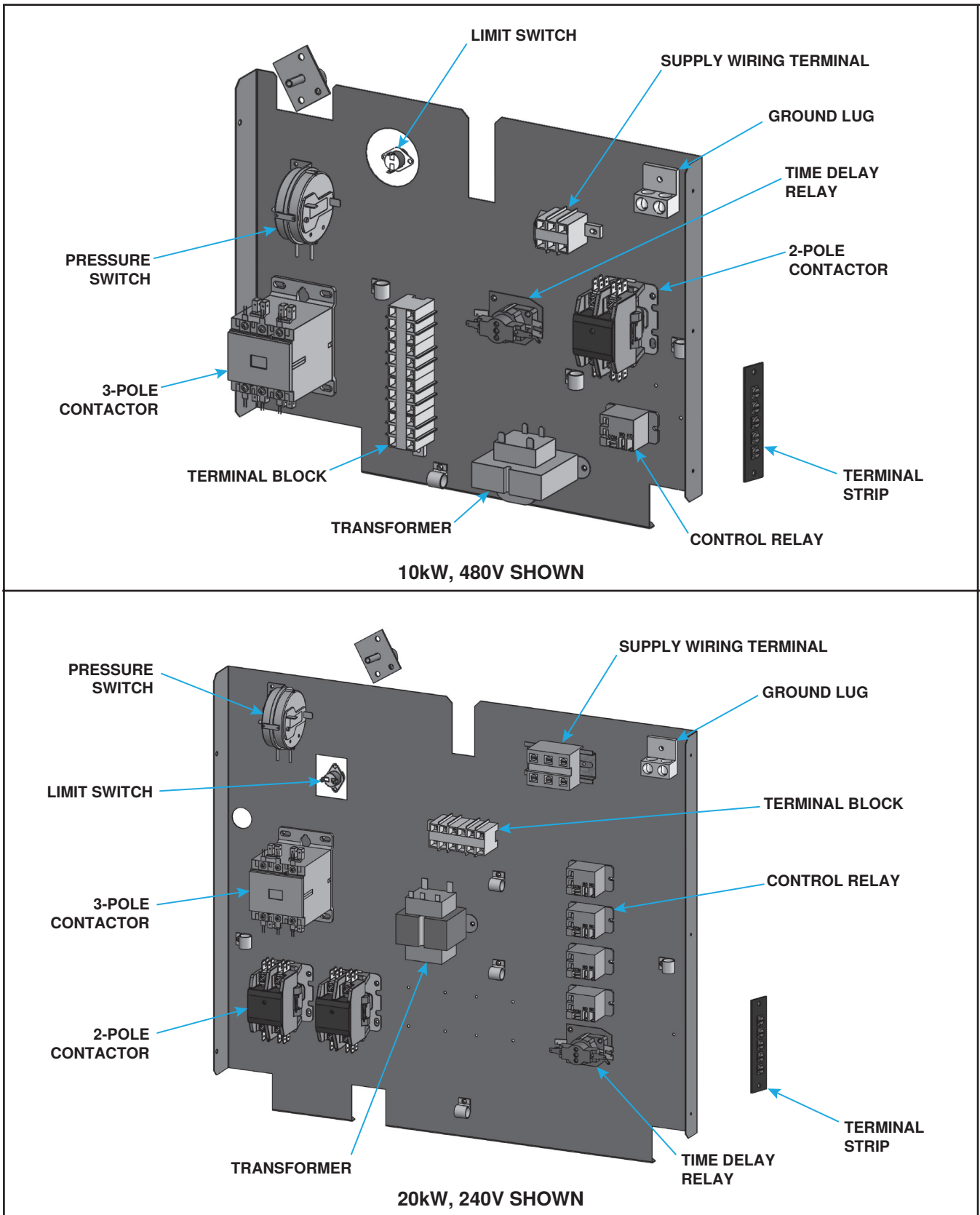

Figure 6. Typical Control Panels

INSTALLATION—CONTINUED

Electrical Connections—Continued

Supply Wiring Connection—Continued

- Route supply wiring through entrance shown in [Figure 7](#) and connect to supply wiring terminal block shown in [Figure 6](#)).

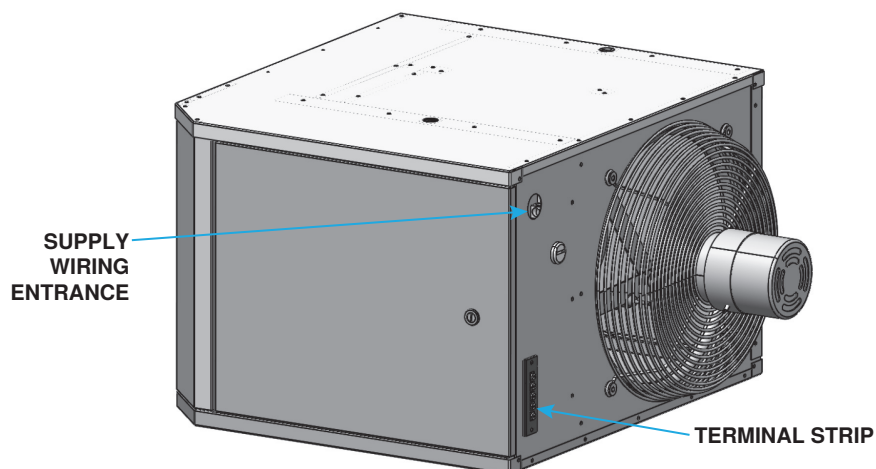

Figure 7. Supply Wiring Entrance and Control Connection Terminal Strip

Control Connections

- The terminal strip for 24V control connections is located on the outside of the cabinet at the back of the unit, as shown in [Figure 7](#). The strip has five terminals: C, R, G, W1, and W2. The thermostat connections are the C (optional), R, G, W1, and W2 (optional) terminals.
- If the installation features a heater and a model H destratification fan controlled by a single two-stage thermostat, ensure that the wiring is in accordance with the wiring diagram shown in [Figure 8](#).

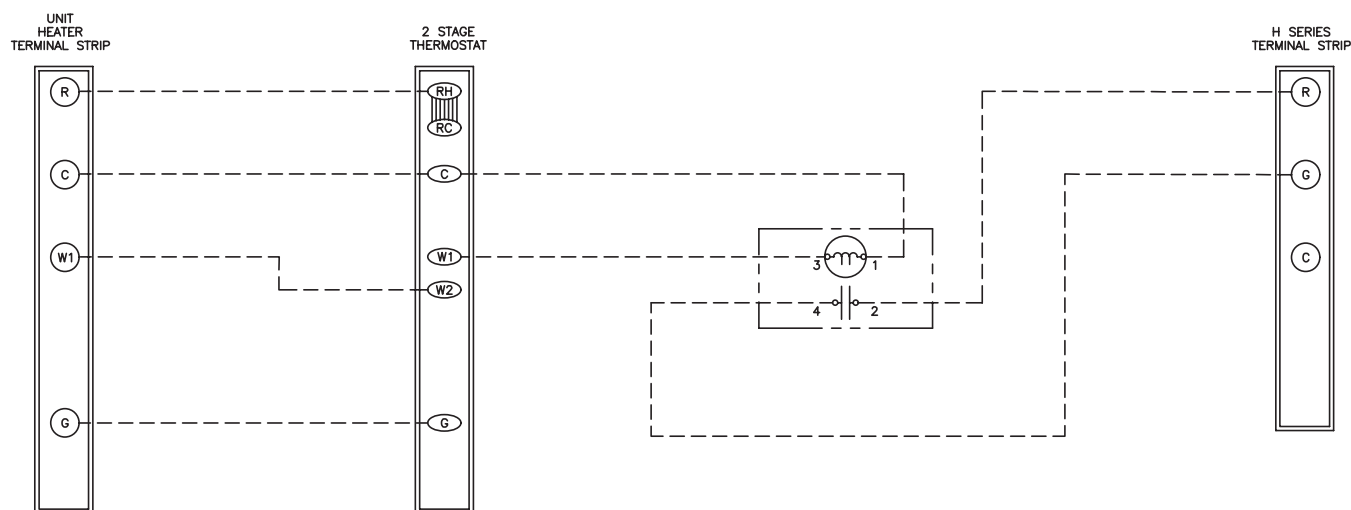

Figure 8. Heater and Destratification Fan Wiring Diagram

CONTROLS

Disconnect Switch

A disconnect switch is available as optional equipment (refer to [Table 5](#)) or it may be field-supplied. When installing the disconnect switch on the back of the unit, allow at least 4 feet (1.2 meters) of service room between the switch and any service panels and ensure that conduit and the switch housing are clear of all service doors. Install the switch in accordance with the *National Electric Code* (ANSI/NFPA 70) or, in Canada, the *Canadian Electric Code* (Part 1, CSA C.22.1).

Fan Motor

The fan motor is equipped with automatic-reset thermal overload protection. If the motor does not run, the cause may be due to improper voltage. Ensure that the correct voltage is available at the motor.

Thermostat

The unit may be controlled by a thermostat—either an optional thermostat (refer to [Table 5](#)) or a field-supplied 24V thermostat that must be field-installed in accordance with the thermostat manufacturer's instructions. Pay particular attention to the requirements regarding the location of the thermostat. In accordance with the wiring diagram provided with the unit, connect the thermostat at the 24V control wiring terminal strip on the back of the unit (refer to [Control Connections](#) section).

Air Proving Pressure Switch

⚠ WARNING ⚠

The automatic-reset air proving pressure switch will continue to shut down the unit until the cause is corrected. Never bypass this switch as hazardous conditions could result.

All units are equipped with a normally-open automatic-reset air proving pressure switch (see [Figure 6](#)) that senses air pressure provided by fan operation. The switch is factory-set and is non-adjustable. When the setpoint is satisfied, the switch allows electric supply to the heating elements. This safety device provides protection in the case of fan motor failure or lack of airflow due to a restriction at the inlet or outlet.

High Temperature Limit Switch

⚠ WARNING ⚠

The automatic-reset high temperature limit switch will continue to shut down the unit until the cause is corrected. Never bypass this switch as hazardous conditions could result.

All units are equipped with a normally-closed temperature-activated, automatic-reset high temperature limit switch (see [Figure 6](#)). The switch is factory-set and is non-adjustable. If the setpoint is reached, the switch interrupts the electric supply to the heating elements. This safety device provides protection in the case of fan motor failure or lack of airflow due to a restriction at the inlet or outlet.

Multiple Unit Control

If the unit was ordered with a multiple unit control option, one thermostat can be used to control up to five units. This option includes a relay assembly that attaches to each additional unit. Option CL31 provides for control of two units. If control of additional units is desired (up to five total), option CL32, which is the relay assembly only, must be added to each additional unit. The option packages are shipped separately and include complete instructions on installation and wiring.

OPERATION

Pre-Startup Checklist

Check the following **before** startup:

- Check to ensure that all screws used to secure shipping brackets have been re-installed in unit cabinet.
- Check suspension—unit must be secure and level.
- Check to ensure that clearances from combustibles are in accordance with [Table 4](#).
- Check electrical wiring—ensure that all wire gauges are as recommended—service disconnect switch should be used—verify that fusing or circuit breakers are adequate for load use.
- Check polarity—verify that line voltage exists between all power wires and earth ground.
- Place literature bag that contains limited warranty form, this manual, and any control or optional information in accessible location near unit.

Startup

Start up the unit as follows:

1. Set thermostat to desired setting.
2. Turn ON electric power to unit.
3. Observe startup sequence (refer to [Table 6](#)).

Condition	Action
Thermostat calls for heat	Terminal W energized
	Fan energized
	Air proving pressure switch closes
	Heating elements energized
Steady heat	Heating elements and fan remain energized
Thermostat is satisfied	Heating elements de-energized
	Fan de-energized when time delay is satisfied

MAINTENANCE

⚠ WARNING ⚠

- Ensure that the disconnect switch is OFF before servicing the unit.
- Wait until the housing and heating elements cool before performing maintenance.
- Eye protection is recommended when cleaning unit.
- Heating elements have sharp edges—wear gloves when handling.

⚠ CAUTION ⚠

- When any service is completed, ensure that the unit is reassembled correctly so that no unsafe conditions are created.
- If any of the original wire supplied with the unit must be replaced, the wiring material must have a temperature rating of at least 220°F (105°C).
- Ensure that all wiring is in accordance with the wiring diagram provided with the unit.
- If replacement parts are required, use only factory-authorized parts.

NOTE: To ensure long life and satisfactory performance, a unit that is operated under normal conditions should be inspected and cleaned at the start of each heating season. If the unit is operating in an area where an unusual amount of dust or soot or other impurities are present in the air, more frequent maintenance is recommended.

The unit is designed to operate with a minimum of maintenance. However, to ensure long life and satisfactory performance, routine service is recommended. When servicing, follow standard safety procedures and the specific instructions and warnings in this manual.

Service Checklist

The following section is designed to aid a qualified service person in maintaining and servicing this equipment. At a minimum, perform the following annually:

- Clean all dirt, lint, and grease from fan blade, fan guard, and motor.
- Replace any parts that do not appear sound.
- Check for any damaged wiring and replace as necessary.

Maintenance Procedures

Electrical Component Replacement

Use a voltmeter to verify that there is 24V output from the transformer. If the transformer is not functioning, it must be replaced. If it is determined that an electrical component needs replacing, use only the factory-authorized replacement part that is designed for the unit.

Fan and Motor Assembly Maintenance

Inspect and clean the motor, fan guard, and blades. Remove any dirt and grease. Take care when cleaning the fan blades so as not to cause misalignment or imbalance. Check to ensure that the hub of the fan blades is secure to the shaft. If necessary, replace the assembly as follows:

1. Turn OFF electric power to unit.
2. Remove access panel and disconnect fan motor wires, capacitor wires at capacitor, and ground screw.
3. Remove assembled parts (fan guard, motor, and fan blade).
4. Disassemble and replace part(s) as needed.
5. Reassemble using replacement part(s) as needed and original parts.
6. Ensure that fan is in proper position on shaft (see [Figure 9](#)) and setscrew is tightened in accordance with torque listed in [Table 7](#).
7. Position assembly on unit and secure fan guard.
8. Rotate fan blade to check for adequate clearance. If adjustment is required, loosen mounting screws, reposition fan guard, and tighten screws to 30 inch-pounds. Repeat until assembly is positioned properly.
9. Reconnect fan motor wires in accordance with wiring diagram.
10. Install access panel.
11. Turn ON electric power to unit and check for proper operation.

MAINTENANCE—CONTINUED

Maintenance Procedures—Continued

Fan and Motor Assembly Maintenance—Continued

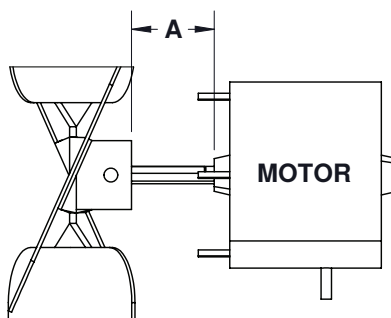

Figure 9. Fan and Motor Spacing (Refer to Table 7)

Table 7. Fan Blade-to-Motor Spacing		
Unit Size (kW)	Dimension A* (Inches (mm))	Setscrew Torque (Inch-Pounds ±10)
3, 5	1 (25)	80
7	1-1/16 (27)	
10	1-1/2 (38)	
15, 20	2-5/16 (59)	120
25, 30	2-1/8 (54)	

*See Figure 9.

TROUBLESHOOTING

Table 8. Troubleshooting			
Symptom	Probable Cause	Remedy	
A. Unit will not start	1. No power to unit	Turn ON power and check supply fuses or circuit breaker	
	2. No 24V power to thermostat		Turn up thermostat
			Check control transformer output
			Replace transformer as necessary
	3. No power to fan motor	Tighten connections at motor terminals	
B. No heat (fan operating)	1. Improper thermostat location or adjustment	Refer to thermostat manufacturer's instructions	
	2. Defective electrical component (pressure switch, limit switch, relay, or contactor)		Replace electrical component(s) as necessary
		3. Defective heating element	Replace heating element
	C. Fan motor will not run	1. Circuit open	Check wiring and connections
		2. Defective electrical component (pressure switch, limit switch, relay, or contactor)	
3. Defective capacitor			Replace capacitor
4. Defective fan motor		Replace fan motor	
D. Fan motor cuts out on overload	1. Poor airflow	Clean motor, fan, and fan guard	
		Adjust louvers	
	2. Low or high voltage supply	Correct electric supply	
	3. Defective capacitor	Replace capacitor	
4. Defective fan motor	Replace fan motor		

APPENDIX: WIRING DIAGRAMS

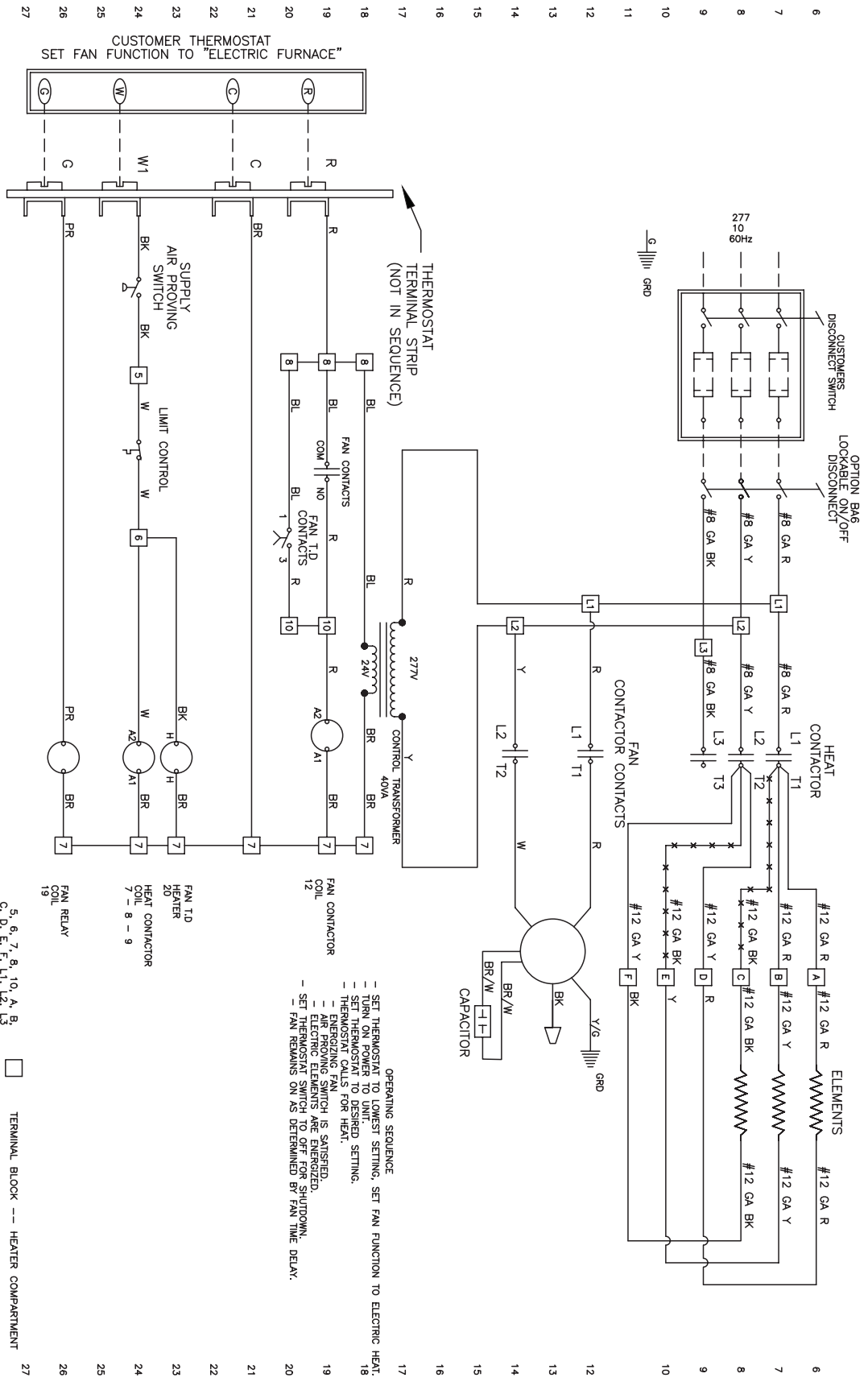

AK4 Wiring Diagram

APPENDIX: WIRING DIAGRAMS—CONTINUED

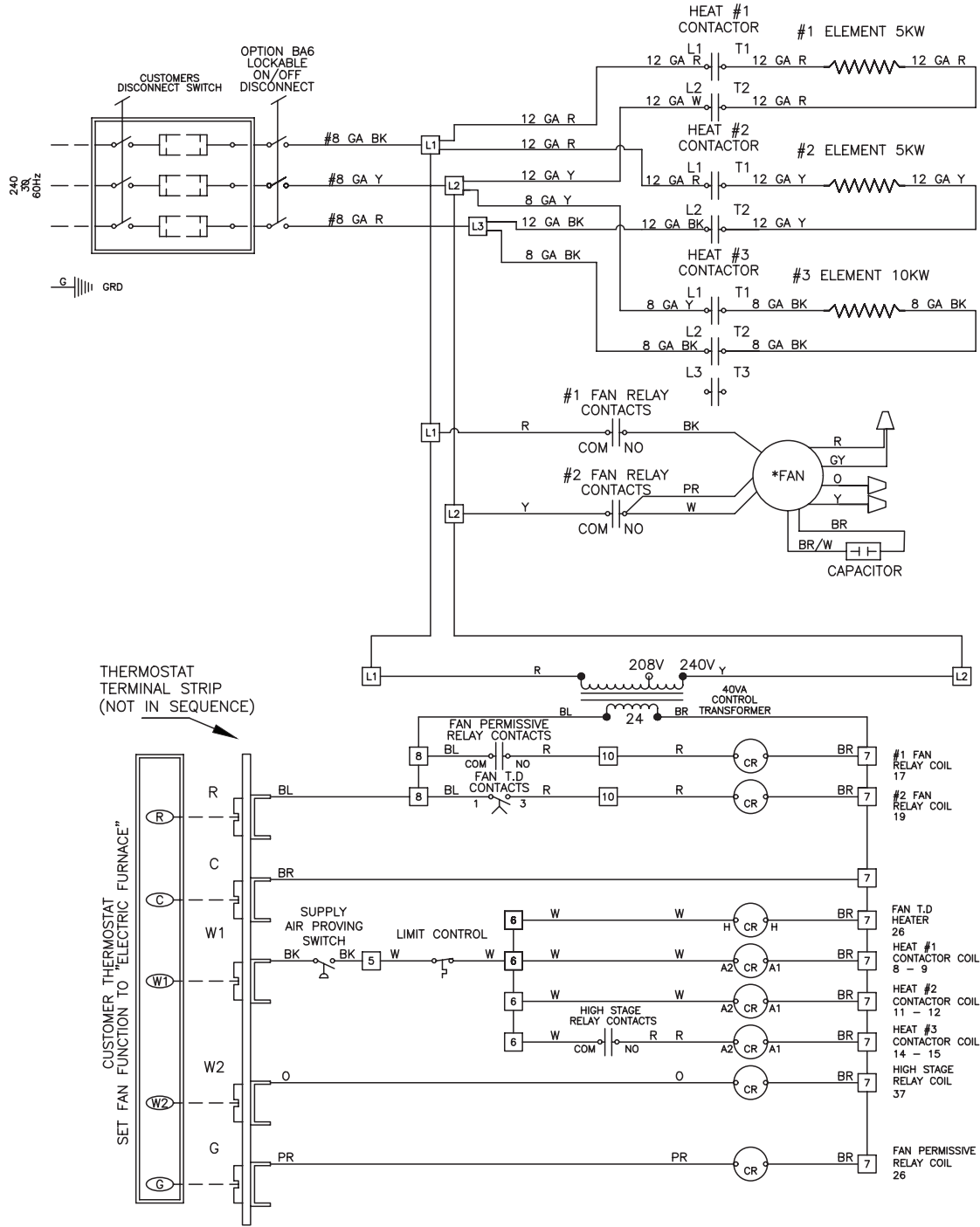

- OPERATING SEQUENCE**
- SET THERMOSTAT TO LOWEST SETTING, SET FAN FUNCTION TO ELECTRIC HEAT.
 - TURN ON POWER TO UNIT.
 - SET THERMOSTAT TO DESIRED SETTING.
 - THERMOSTAT CALLS FOR HEAT.
 - ENERGIZING FAN
 - AIR PROVING SWITCH IS SATISFIED.
 - ELECTRIC ELEMENTS ARE ENERGIZED.
 - SET THERMOSTAT SWITCH TO OFF FOR SHUTDOWN.
 - FAN REMAINS ON AS DETERMINED BY FAN TIME DELAY.
- 5, 6, 7, 8, 10, L1, L2, L3 □ TERMINAL BLOCK -- HEATER COMPARTMENT

AK6E Wiring Diagram

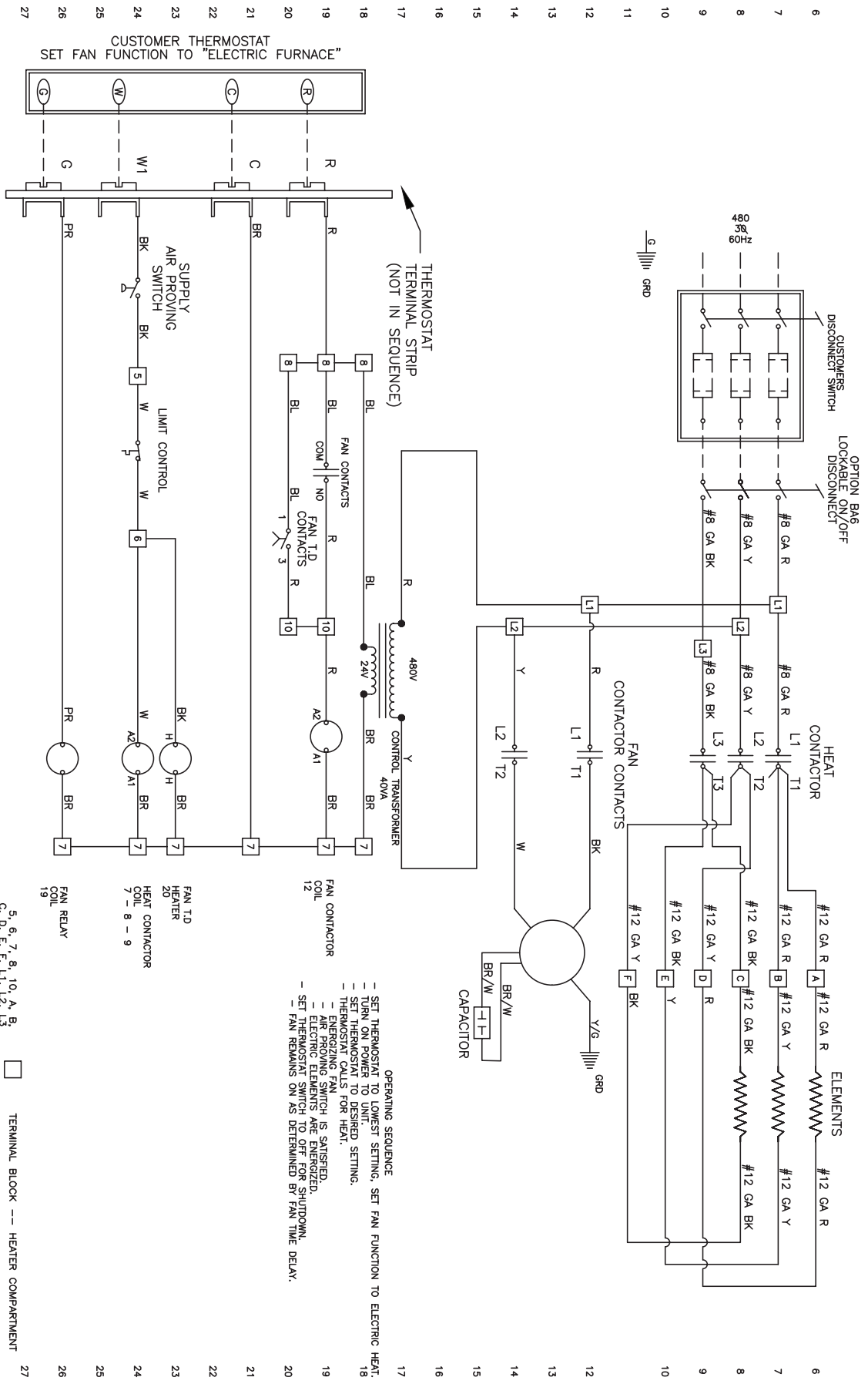

AK7E Wiring Diagram—Unit Sizes 3 through 10

APPENDIX: WIRING DIAGRAMS—CONTINUED

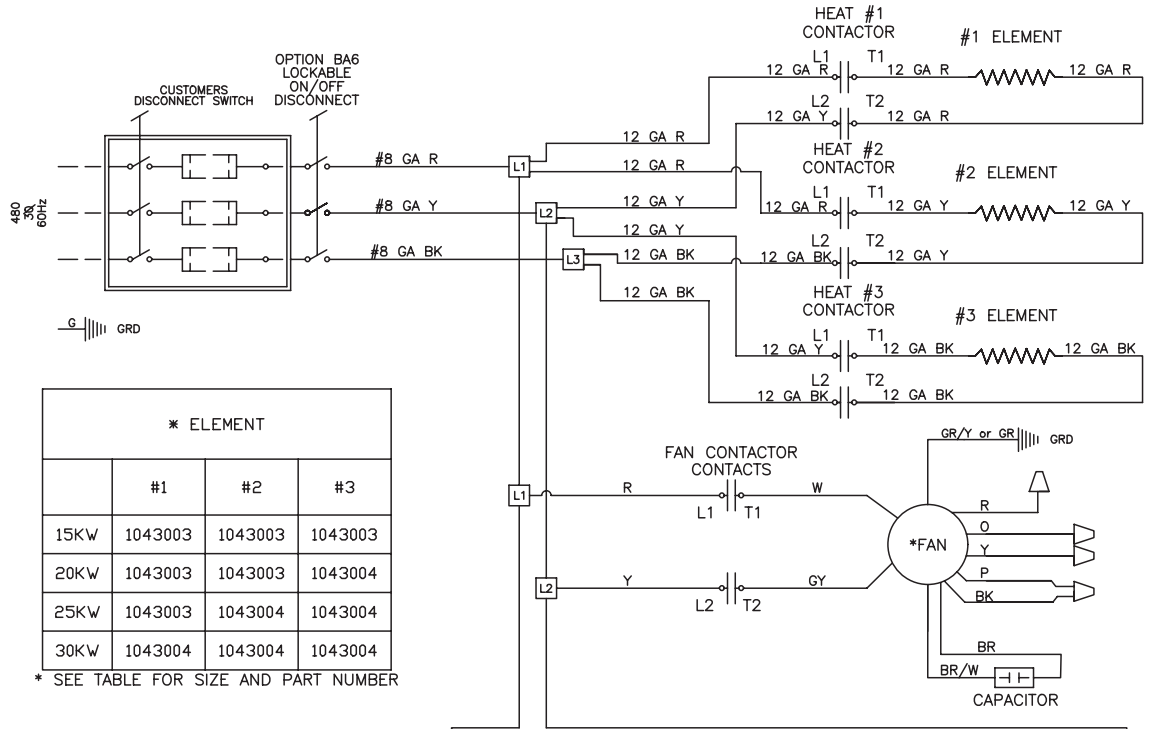

* ELEMENT

	#1	#2	#3
15KW	1043003	1043003	1043003
20KW	1043003	1043003	1043004
25KW	1043003	1043004	1043004
30KW	1043004	1043004	1043004

* SEE TABLE FOR SIZE AND PART NUMBER

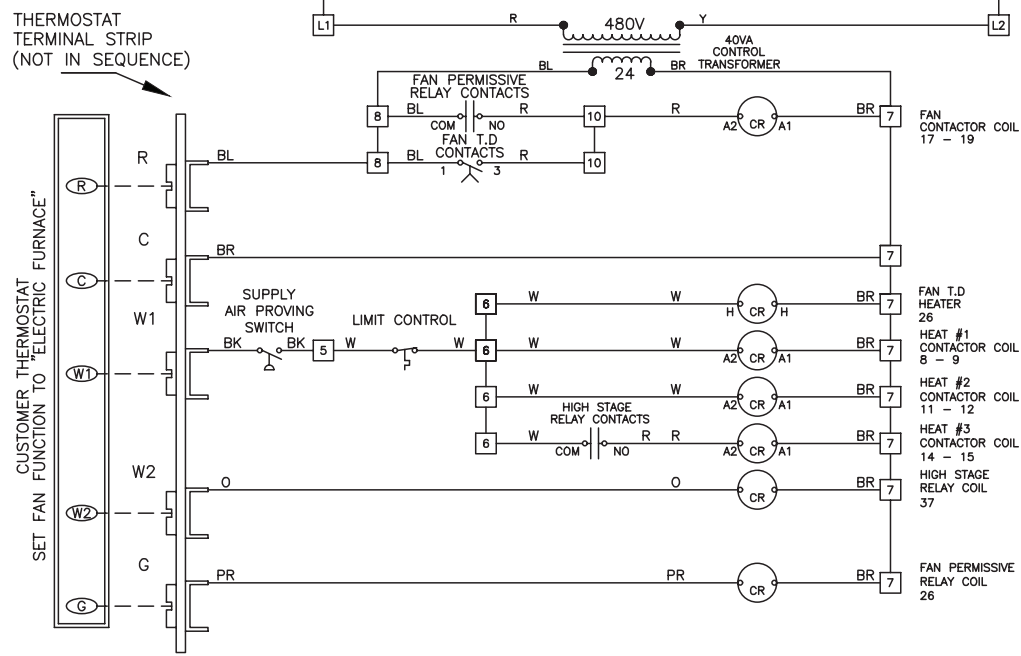

- OPERATING SEQUENCE
- SET THERMOSTAT TO LOWEST SETTING, SET FAN FUNCTION TO ELECTRIC HEAT.
 - TURN ON POWER TO UNIT.
 - SET THERMOSTAT TO DESIRED SETTING.
 - THERMOSTAT CALLS FOR HEAT.
 - ENERGIZING FAN
 - AIR PROVING SWITCH IS SATISFIED.
 - ELECTRIC ELEMENTS ARE ENERGIZED.
 - SET THERMOSTAT SWITCH TO OFF FOR SHUTDOWN.
 - FAN REMAINS ON AS DETERMINED BY FAN TIME DELAY.

5, 6, 7, 8, 10, L1, L2, L3 □ TERMINAL BLOCK -- HEATER COMPARTMENT

AK7E Wiring Diagram—Unit Sizes 15 through 30

7
8
9
10
11
12
13
14
15
16
17
18
19
20
21
22
23
24
25
26
27
28
29
30
31
32
33
34
35
36

7
8
9
10
11
12
13
14
15
16
17
18
19
20
21
22
23
24
25
26
27
28
29
30
31
32
33
34
35
36

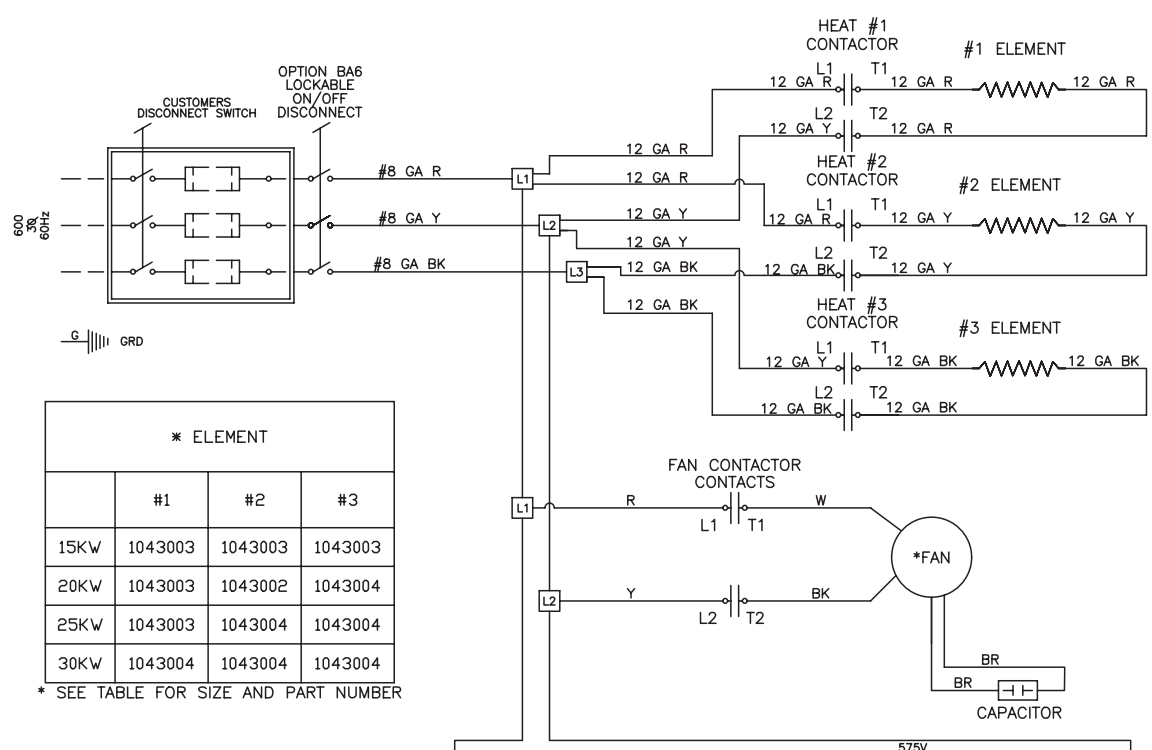

* ELEMENT

	#1	#2	#3
15KW	1043003	1043003	1043003
20KW	1043003	1043002	1043004
25KW	1043003	1043004	1043004
30KW	1043004	1043004	1043004

* SEE TABLE FOR SIZE AND PART NUMBER

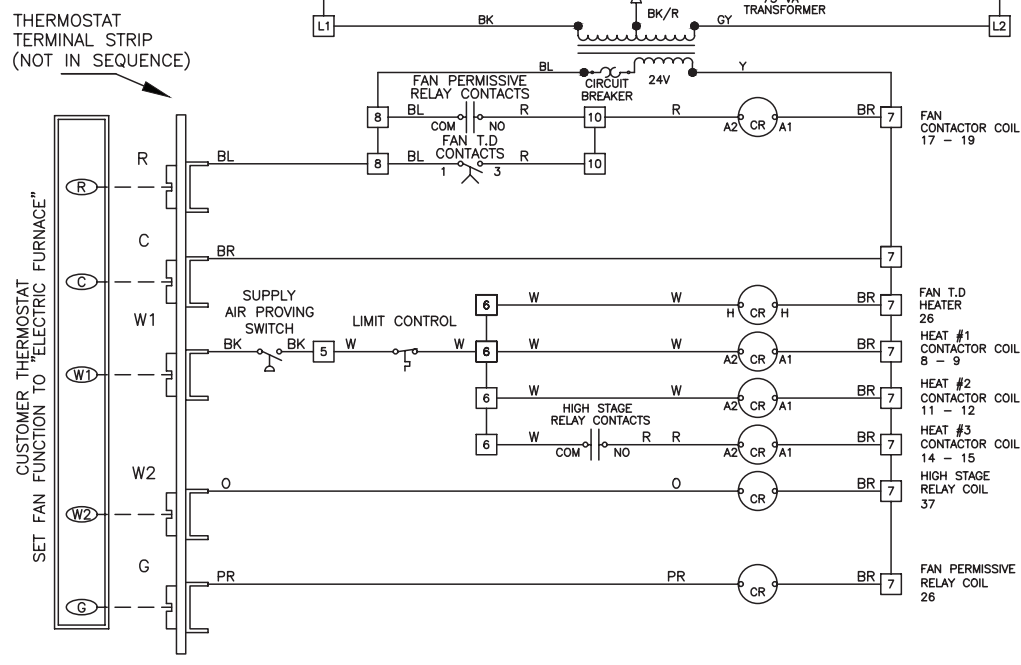

- OPERATING SEQUENCE
- SET THERMOSTAT TO LOWEST SETTING, SET FAN FUNCTION TO ELECTRIC HEAT.
 - TURN ON POWER TO UNIT.
 - SET THERMOSTAT TO DESIRED SETTING.
 - THERMOSTAT CALLS FOR HEAT.
 - ENERGIZING FAN
 - AIR PROVING SWITCH IS SATISFIED.
 - ELECTRIC ELEMENTS ARE ENERGIZED.
 - SET THERMOSTAT SWITCH TO OFF FOR SHUTDOWN.
 - FAN REMAINS ON AS DETERMINED BY FAN TIME DELAY.

5, 6, 7, 8, 10, L1, L2, L3 □ TERMINAL BLOCK -- HEATER COMPARTMENT

AK8E Wiring Diagram

APPENDIX: WIRING DIAGRAMS—CONTINUED

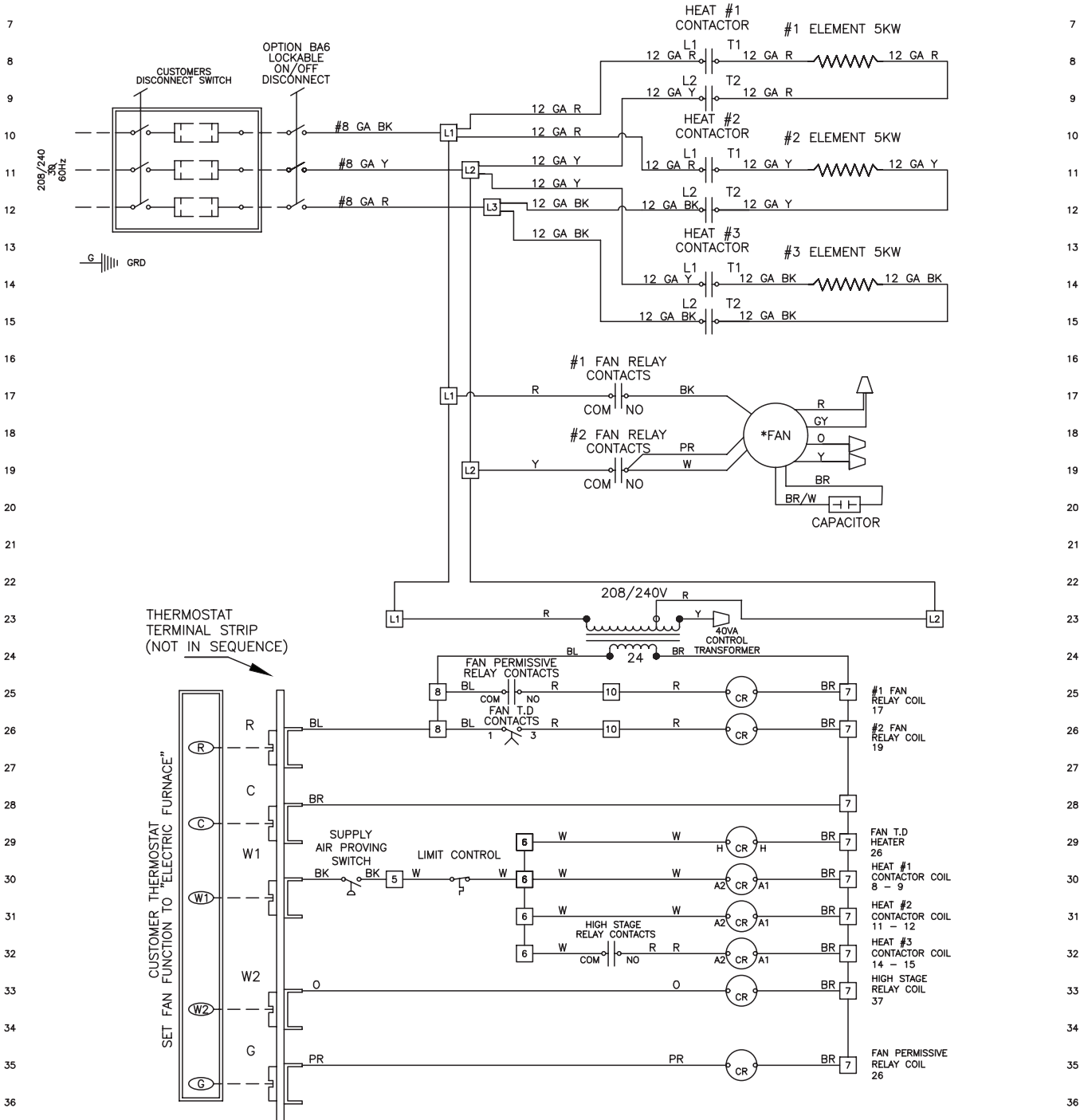

- OPERATING SEQUENCE**
- SET THERMOSTAT TO LOWEST SETTING, SET FAN FUNCTION TO ELECTRIC HEAT.
 - TURN ON POWER TO UNIT.
 - SET THERMOSTAT TO DESIRED SETTING.
 - THERMOSTAT CALLS FOR HEAT.
 - ENERGIZING FAN
 - AIR PROVING SWITCH IS SATISFIED.
 - ELECTRIC ELEMENTS ARE ENERGIZED.
 - SET THERMOSTAT SWITCH TO OFF FOR SHUTDOWN.
 - FAN REMAINS ON AS DETERMINED BY FAN TIME DELAY.

5, 6, 7, 8, 10, L1, L2, L3 □ TERMINAL BLOCK -- HEATER COMPARTMENT

AK20 Wiring Diagram

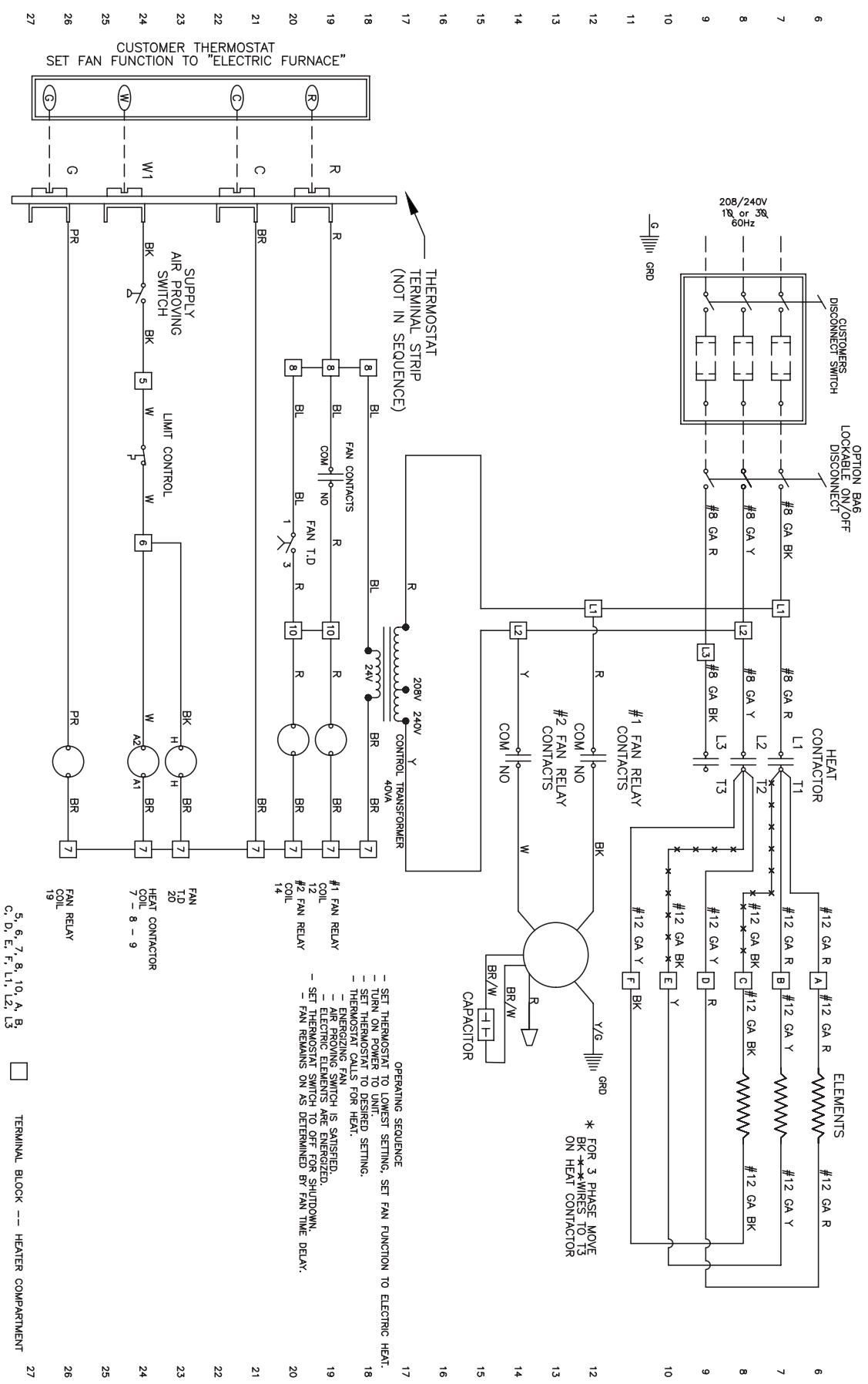

AK44 Wiring Diagram

- OPERATING SEQUENCE
- SET THERMOSTAT TO LOWEST SETTING, SET FAN FUNCTION TO ELECTRIC HEAT.
 - TURN ON POWER TO UNIT.
 - SET THERMOSTAT TO DESIRED SETTING.
 - THERMOSTAT CALLS FOR HEAT.
 - ENERGIZING FAN IS SATISFIED.
 - AIR FLOWING SWITCH IS SATISFIED.
 - FAN REMAINS ON FOR DELAY.
 - SET THERMOSTAT SWITCH TO OFF FOR SHUTDOWN.
 - FAN REMAINS ON AS DETERMINED BY FAN TIME DELAY.

5, 6, 7, 8, 10, A, B, C, D, E, F, L1, L2, L3

□ TERMINAL BLOCK --- HEATER COMPARTMENT

INSTALLATION RECORD (TO BE COMPLETED BY INSTALLER)

Model	Serial No.	Date of Installation	Notes
	Installer	Distributor	
Name			
Company			
Address			
Phone No.			

For more information on Reznor HVAC products:

- Contact your local Reznor representative at 1-800-695-1901
- Refer to the technical specifications, manuals, and consumer materials found at www.reznorhvac.com

